

Standard fixing holes on terminal board opposite side.  
Fixing holes on other sides on demand.

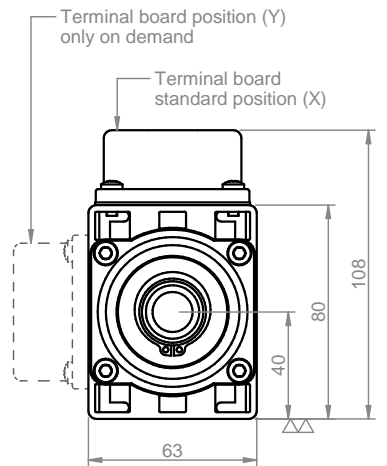

Standard fixing holes on terminal board opposite side.  
Fixing holes on other sides on demand.  
Collets, nuts and wrenches only on demand.

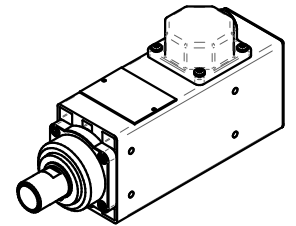
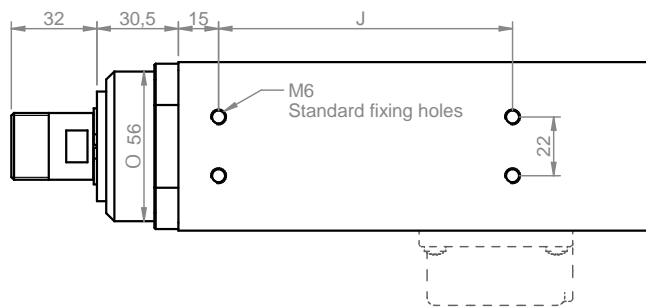
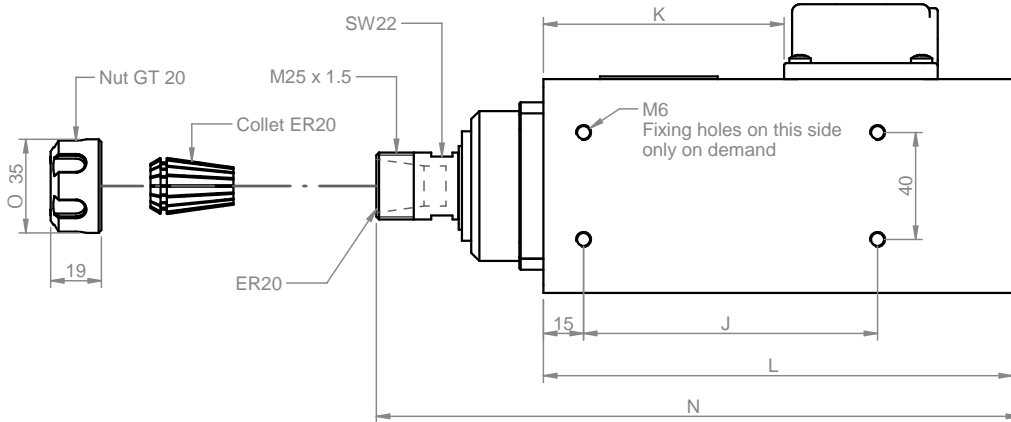

OVERALL DIMENSION					
TYPE	J	K	L	M	N
3140-A	85	65.5	150.5	186.9	215.7
3140-B	110	90.5	175.5	211.9	240.7
3140-C	110	110.5	195.5	231.9	260.7
3140-D	110	130.5	205.5	241.9	270.7